



DAB 5 Bar Pressure Switch

DAB-5BARPS - 701440



1. Introduction

The DAB 5 Bar pressure switch by MAC3 is a robust mechanical pressure switch intended for use on water pumps.





Cut In is set at 2.0 bar and Cut Out is set at 3.5 bar which is suitable for most domestic installations. Both settings are adjustable independently.

2. Specifications

- Rated voltage: 110 – 240V
- Rated current: 16A resistive, (8 amp inductive)
- Pressure Range: 1 bar - 5 bar
- Pre-set Pressure Setting: Cut in 2.0 bar, Cut out 3.5 bar
- Protection Grade: IP54
- Ambient Temperature range: -20 - 80°C
- Liquid Temperature range: 0 - 50 °C
- Connection 1/8" BSP Female swivel fitting
- 3mm orifice



3. Warnings

	Read the manual carefully before starting
	Prior to starting installation or any maintenance the power supply must be disconnected and, pressure relieved from the system including pump and associated pipework.
	Fitment and replacement must be carried out by competent, skilled, qualified personnel Any changes or modification to the wiring must be carried out by suitably qualified personnel.
	A qualified electrician should correctly size and install circuit breakers to protect the power supply. The fitment of additional surge protection is recommended.
	This appliance is not intended for use by persons (including children) with reduced physical, sensory or mental capabilities, or lack of experience and knowledge, unless they have been given supervision or instruction concerning use of the appliance by a person responsible for their safety. Children should be supervised to ensure that they do not play with the appliance.

4. Wiring and Adjustment

Wiring shown is for single phase

Maximum allowable voltage 240V

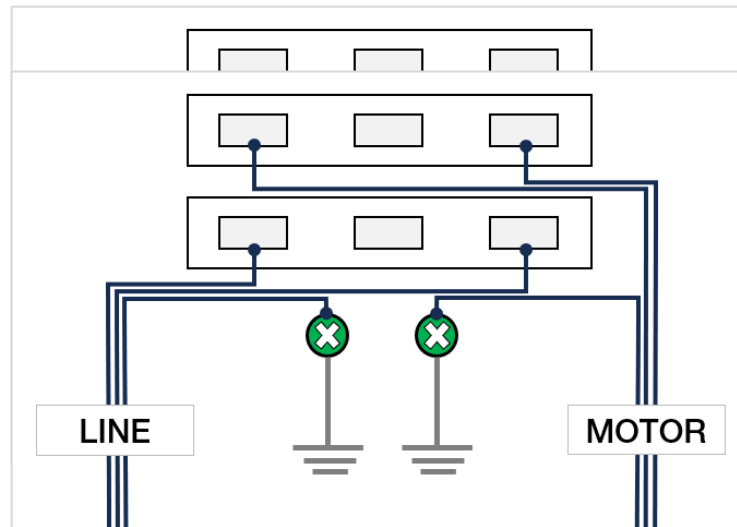

Pre-set Pressure Setting: Cut in 2.0 bar, Cut out 3.5 bar

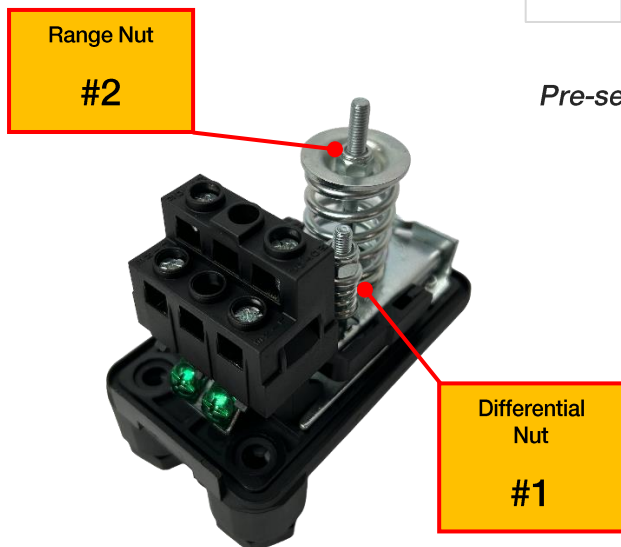

To Change Pressure Setting

Tighten Differential Nut #1 completely

Adjust range nut #2 to the desired cut-in (pump start) pressure

Adjust the Differential Nut #1 to the desired cut-out (pump stop) pressure

Adjust the cut-out (#1) on rising pressure

Adjust the cut-in (2) on falling pressure

Pumps controlled with a pressure switch must be fitted with a pressure vessel sized to ensure the pump starts per hours do not exceed the manufacturers recommendation.

Pressure vessel pre-charge should be 66% of the cutout pressure.

Should 66% be substantially less than 0.1bar under cut-in the tank pre-charge can be set to the higher value.



5. Trouble Shooting Guide

Fault	Possible Cause	Remedy
The motor does not start	<ul style="list-style-type: none"> A. Check the pressure switch is live. B. Ensure the pressure vessel pre-charge is lower than the cut-in (pump start) pressure. 	<ul style="list-style-type: none"> A. Check the power supply circuit breaker(s) B. Adjust the pressure tank pre-charge
The motor does not stop when the demand for water has ceased	<ul style="list-style-type: none"> A. Ensure the Pressure Switch cut-out (pump stop) setting does not exceed the ability of the pump to generate pressure. B. Check the pressure switch contacts move freely 	<ul style="list-style-type: none"> A. Adjust the pressure switch B. Replace the pressure switch
The pump is cycling (stopping and starting) frequently	<ul style="list-style-type: none"> A. Ensure the Pressure Switch cut-out (pump stop) setting is not too low. If the pressure the pump develops at the duty flow is higher than the cut-out setting, the pump will cycle. B. Ensure the pressure tank is large enough, that the internal bladder or diaphragm has not failed and that the tank pre-charge is correct 	<ul style="list-style-type: none"> A. Adjust the pressure switch B. Adjust or replace the pressure vessel

Note: Water containing minerals and/or fine sediment can build up inside the wetted part of the switch and prevent it from operating.

Should the switch jam in the ON position the pump may suffer terminal damage.

Dry run protection, Maximum run-time protection or Source Water level cutout device(s) should be considered.



6. Warranties – Terms and Conditions

This warranty is given in addition to the consumer guarantees found within the Australian Competition and Consumer Act 2010 (Cth) for goods purchased in Australia and the Consumer Guarantees Act 1993 NZ for goods purchased in New Zealand:



1) White International Pty Ltd / White International NZ Ltd (White International) warrant that all products distributed are free from defects in workmanship and materials, for their provided warranty period as indicated on the top or opposite side of this document. Subject to the conditions of the warranty, White International will repair any defective products free of charge at the premises of our authorised service agents throughout Australia and New Zealand if a defect in the product appears during the warranty period. If you believe that you have purchased a defective product and wish to make a claim under this warranty, contact us on our Sales Hotline on 1300 783 601, or send your claim to our postal address or fax line below and we will advise you as to how next to proceed. You will be required to supply a copy of your proof of purchase to make a claim under this warranty.

2) This warranty excludes transportation costs to and from White International or its appointed service agents and excludes defects due to non-compliance with installation instructions, neglect or misuse, inadequate protection against the elements, low voltage or use or operation for purposes other than those for which they were designed. For further information regarding the suitability of your intended application contact us on our Sales Hotline on 1300 783 601. If you make an invalid claim under this warranty, the original product will be sent back to you unrepai red.

3) This warranty refers only to products sold after the 1st January 2012, and is not transferable to another product type and only applies to the original owner, purchaser or end user, and is in addition to the consumer guarantees found within the Competition and Consumer Act 2010 (Cth) for goods purchased in Australia and the Consumer Guarantees Act 1993 (NZ) for goods purchased in New Zealand.

4) Our goods come with guarantees that cannot be excluded under the Australian Consumer Law. You are entitled to a replacement or refund for a major failure and for compensation for any other reasonably foreseeable loss or damage. You are also entitled to have the goods repaired or replaced if the goods fail to be of acceptable quality and the failure does not amount to a major failure. 2 YEAR WARRANTY.

5) To the fullest extent permitted by law, White International excludes its liability for all other conditions or warranties which would or might otherwise be implied at law. To the fullest extent permitted by law, White International's liability under this warranty and any other conditions, guarantees or warranties at law that cannot be excluded, including those in the Competition and Consumer Act 2010 (Cth), is expressly limited to: (a) in the case of products, the replacement of the product or the supply of equivalent product, the payment of the cost of replacing the product or of acquiring an equivalent product or the repair of the product or payment of the cost of having the product repaired, is at the discretion of White International or a 3rd party tribunal elected under the Competition and Consumer Act 2010 (Cth) for goods purchased in Australia and the Consumer Guarantees Act 1993 (NZ) for goods purchased in New Zealand; and

6) To the fullest extent permitted by law, this warranty supersedes all other warranties attached to the product or its packaging.

7) In the case of services, supplying the services again or the payment of the cost of having the services supplied again, is at the discretion of White International or a 3rd party tribunal elected under the Competition and Consumer Act 2010 (Cth) for goods purchased in Australia and the Consumer Guarantees Act 1993 (NZ) for goods purchased in New Zealand. 8) Our warranty commences from the date of purchase of the above mentioned pumps. Proof of purchase is required before consideration under warranty is given.

Record your date of purchase in the space below and retain this copy for your records.

Date of Purchase**Model Purchased**



www.whiteint.com.au

www.whiteint.co.nz

Please always refer to our website for further technical information & new product innovations

Disclaimer: Every effort has been made to publish the correct information in this manual.
No responsibility will be taken for errors, omissions or changes in product specifications.

© 2023 Copyright White International Pty Ltd

TM ® - WARNING: Please be aware that various brands & products depicted within this document are subject to trademark, patent or design registrations. Infringement of any intellectual property contained within this document without express written authority by the appropriate intellectual property holder may result in further legal action to be taken. For any queries regarding use of the contained information please feel free to contact White International Pty Ltd.